



Treedom

Product by LSG

ACOUSTIC LEARNING TREE

0508 476 227
 inspire@lsg.co.nz
 lsg.co.nz

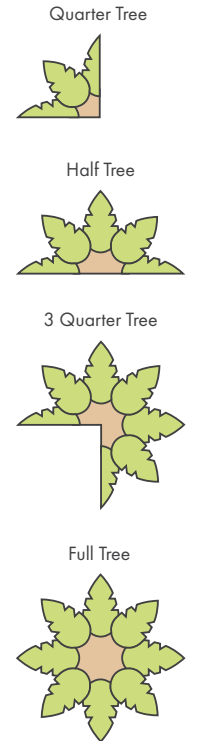
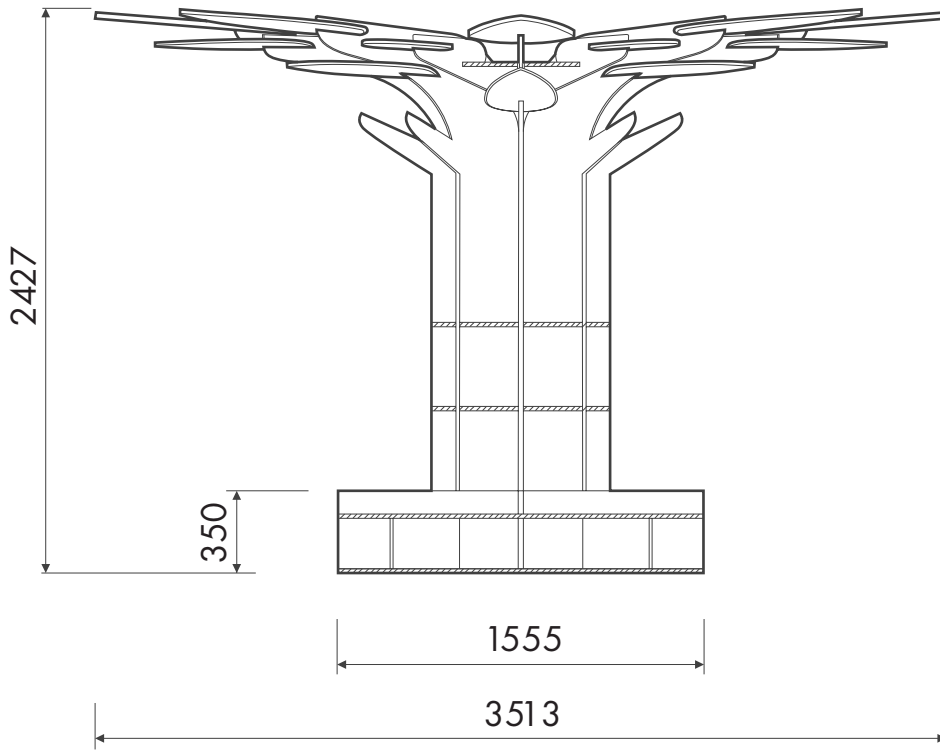

ESTABLISHED LEARNING AND WELLNESS BENEFITS INCLUDE;



Biophilic Tree design brings the outdoors indoors to enhance the natural learning environment and helps children connect with our natural surroundings.



Increases warmth and natural atmosphere in learning spaces to help children feel more inclusive.



Woven to precise specifications with high abrasion standards, repels stains for easy clean, highly durable, heavy commercial rub resistant fabric. Fire rated to AS/NZS 15-30.3



Reduces harsh noises from reverberation around the large open spaces, ideal for quiet zones, ILE areas, libraries, and collaboration spaces.



Promotes collaboration, togetherness and unity, and provides a 'Go to place' for those needing support.



The Acoustic Learning Tree is available in quarter, half, 3 quarter and full circle configurations. Perfect for any space!



Encourages a greater sense of wellness and calmness amidst overstimulated environments and spaces.



Strong and Durable European birch plywood construction, perfect for high-use environments



This tree comes with our most popular BEECH LEAVES in a soft green acoustic foam. But ask our team if you wish to customise these leaves to suit your own learning theme.

